



Machine Packaging Capabilities: Edible Oil, Ghee, Vanaspati, Pasteurized Fruit Pulp, Mango Pulp, Fresh Cream, Water and Lubrication Oil.

Salient Features

- Twin head construction with independent head operation
- Enclosed SS cabinet construction for hygienic operation
- Shut-Off valve for product ON/OFF
- Special Horizontal press system
- Thyristorized heat control system
- Independent mechanism for both head
- Operator friendly Programmer cam controller
- Pouch style options – center seal pouch with increased panel area
- Advanced linearly adjustable impulse sealing system
- Specially designed film roll unwinding mechanism for smooth bag pulling operation
- Independent operation for sealing & film feed operations for optimum performance
- Less floor space requirement for machine installation as no side opening required
- Bag unwinding by pressure rubber rollers coupled with special clutch brake system.
- Suitable for different range of packaging film i.e PE based film with or without laminates
- Machine operation on Electro –Mechanical Principle.
- Adjustable Bag length
- Flexible vertical seal jaw positioning to offer range of variable pack with offering quick change-over facility

Technical Specifications	
Output Quantity	200 ml – 2000 ml
Output	3000 ~ 4800 packs / hr.
Filler Accuracy	± 3 gm
Pack / Quantity Range:	
Min. Bag size (W x L) approx.	100 mm x 135 mm
Max. Bag size (W x L) approx.	170 mm x 265 mm
Packaging Material	Co-extruded 3 or 5 Layer PE Based or Laminated, 85 to 120 microns
Film Reel	Core dia 76 mm & Reel diameter 300 mm max
Electrical Requirement	
Input Supply	380 V AC, 50 Hz, 3 ph + N + G
Connected Load	6 KVA
Peak Power Rating	5.5 KW
Cooling Water	
Flow Rate	200 ltr/hr
Temperature Range	6° to 10°C maintained
Minimum Pressure	2 bar

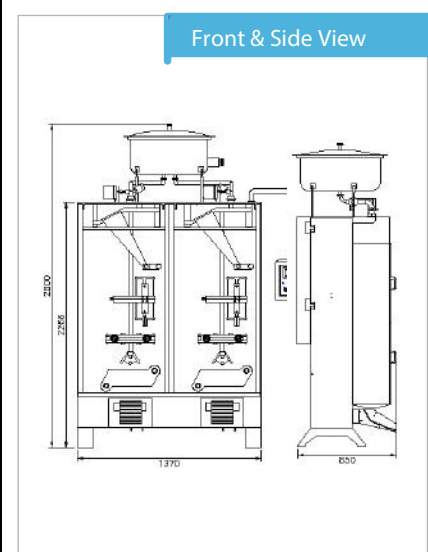

Air Requirement (Optional)	
Air Pressure	6 bar constant dry air
Machine Dimensions(W x D x H) approx.	850 mm x 1370 mm 2800 mm
Weight	1200 kgs (Net)

Optional Accessories

- Customized pack Size
- Water Chiller
- Photomark Registration Unit for Panel Printed Films
- Automatic Pouch Counting System
- Inert Gas Flushing System
- Conveyor
- Gramage control by electric valve on balance tank
- Date Coding System
- Extra Magazine Shaft
- UV sterilization of packaging film
- C.I.P cleaning provision for Milk Packing
- Operator friendly PLC controller
- Special sealing card to control sealing
- End of film roll facility with parking mode interlock
- Safety card for protection of electrical/electronics equipment
- Positive displacement pump filler with fine quantity adjustment facility.
- Equipped with variable speed drive for flexibility to offer adjustable output for the machine
- Door Safety sensor
- SS Body

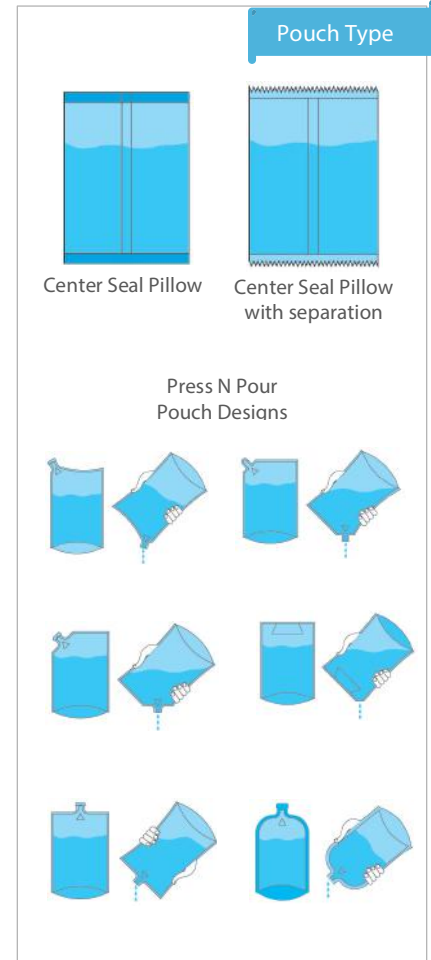

DISCLAIMER: The information on this flyer is accurate to the best of Prepac's knowledge. All our machines can be customized as per customers' requirements and specifications. Machine cost may vary depending on the scope of customization required. The end-user must determine the suitability of the material for a particular application.